

Conexiones Biofarmacéuticas "High Purity"

Codo 45° Soldable - T2KS

D.E. Tubing	A (in)	Acabado PL - SF1	Acabado PM - SF4
1/2"	2.25	T2KS-050PL	T2KS-050PM
3/4"	2.25	T2KS-075PL	T2KS-075PM
1"	2.25	T2KS-100PL	T2KS-100PM
1-1/2"	2.50	T2KS-150PL	T2KS-150PM
2"	3.00	T2KS-200PL	T2KS-200PM
2-1/2"	3.38	T2KS-250PL	T2KS-250PM
3"	3.63	T2KS-300PL	T2KS-300PM
4"	4.50	T2KS-400PL	T2KS-400PM
6"	6.25	T2KS-600PL	T2KS-600PM

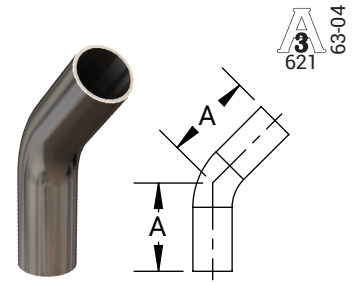

BPE Tabla DT-4.1.1-4
ASME BPE 2019

Codo 45° Clamp x Extremo Soldable - T2KM

D.E. Tubing.	A (in)	B (in)	Acabado PL - SF1	Acabado PM - SF4
1/2"	2.25	1.00	T2KM-050PL	T2KM-050PM
3/4"	2.25	1.00	T2KM-075PL	T2KM-075PM
1"	2.25	1.13	T2KM-100PL	T2KM-100PM
1-1/2"	2.50	1.44	T2KM-150PL	T2KM-150PM
2"	3.00	1.75	T2KM-200PL	T2KM-200PM
2-1/2"	3.38	2.06	T2KM-250PL	T2KM-250PM
3"	3.63	2.38	T2KM-300PL	T2KM-300PM
4"	4.50	3.13	T2KM-400PL	T2KM-400PM
6"	6.25	5.25	T2KM-600PL	T2KM-600PM

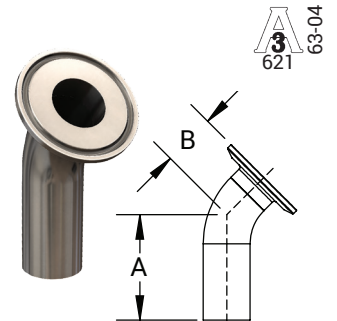

BPE Tabla DT-4.1.1-5
ASME BPE 2019

Codo 45° Clamp x Clamp - T2KMP

D.E. Tubing	A (in)	Acabado PL - SF1	Acabado PM - SF4
1/2"	1.00	T2KMP-050PL	T2KMP-050PM
3/4"	1.00	T2KMP-075PL	T2KMP-075PM
1"	1.13	T2KMP-100PL	T2KMP-100PM
1-1/2"	1.44	T2KMP-150PL	T2KMP-150PM
2"	1.75	T2KMP-200PL	T2KMP-200PM
2-1/2"	2.06	T2KMP-250PL	T2KMP-250PM
3"	2.38	T2KMP-300PL	T2KMP-300PM
4"	3.13	T2KMP-400PL	T2KMP-400PM
6"	5.25	T2KMP-600PL	T2KMP-600PM

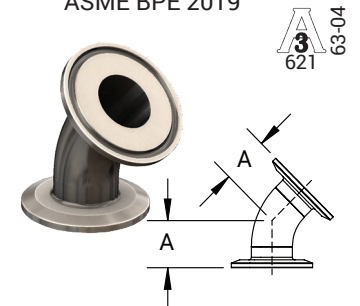

BPE Tabla DT-4.1.1-6
ASME BPE 2019

Codo 88° Soldable - T2S88

D.E. Tubing	A (in)	R (in)	Acabado PL - SF1	Acabado PM - SF4
1/2"	1.94	1.06	T2S88-050PL	T2S88-050PM
3/4"	1.98	1.02	T2S88-075PL	T2S88-075PM
1"	1.50	1.50	T2S88-100PL	T2S88-100PM
1-1/2"	1.50	2.25	T2S88-150PL	T2S88-150PM
2"	1.75	3.00	T2S88-200PL	T2S88-200PM
2-1/2"	1.75	3.75	T2S88-250PL	T2S88-250PM
3"	1.75	4.50	T2S88-300PL	T2S88-300PM
4"	2.00	6.00	T2S88-400PL	T2S88-400PM
6"	2.50	9.00	T2S88-600PL	T2S88-600PM

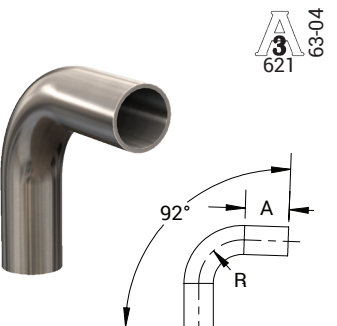

Codo 92° Soldable - T2S92

D.E. Tubing.	A (in)	R (in)	Acabado PL - SF1	Acabado PM - SF4
1/2"	1.94	1.06	T2S92-050PL	T2S92-050PM
3/4"	1.98	1.02	T2S92-075PL	T2S92-075PM
1"	1.50	1.50	T2S92-100PL	T2S92-100PM
1-1/2"	1.50	2.25	T2S92-150PL	T2S92-150PM
2"	1.75	3.00	T2S92-200PL	T2S92-200PM
2-1/2"	1.75	3.75	T2S92-250PL	T2S92-250PM
3"	1.75	4.50	T2S92-300PL	T2S92-300PM
4"	2.00	6.00	T2S92-400PL	T2S92-400PM
6"	2.50	9.00	T2S92-600PL	T2S92-600PM

NOTA: Especificaciones BPE 2019.

Acabado PL – SF1.

D.E. = 32Ra Pulido Mecánico.

D.I. = 20Ra Pulido Mecánico.

Acabado PM – SF4.

D.E. = 32Ra Pulido Mecánico.

D.I. = 15Ra Pulido Mecánico y Electropulido .