

Conexiones Biofarmacéuticas "High Purity"

Tee Extremo Soldable x Extremo Soldable x Extremo Soldable - T7WWW

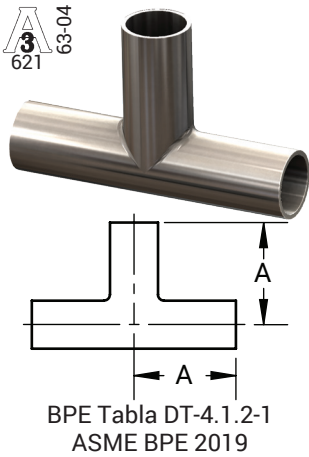

D.E. Tubing	A (in)	Acabado PL - SF1	Acabado PM - SF4
1/2"	1.88	T7WWW-050PL	T7WWW-050PM
3/4"	2.00	T7WWW-075PL	T7WWW-075PM
1"	2.13	T7WWW-100PL	T7WWW-100PM
1-1/2"	2.38	T7WWW-150PL	T7WWW-150PM
2"	2.88	T7WWW-200PL	T7WWW-200PM
2-1/2"	3.13	T7WWW-250PL	T7WWW-250PM
3"	3.38	T7WWW-300PL	T7WWW-300PM
4"	4.13	T7WWW-400PL	T7WWW-400PM
6"	5.63	T7WWW-600PL	T7WWW-600PM

Tee Reductora Extremo Soldable x Extremo Soldable x Extremo Soldable - T7RWWW

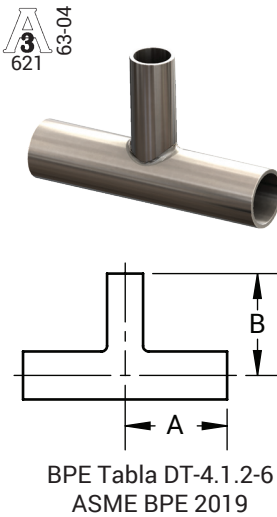

D.E. Tubing	A (in)	B (in)	Acabado PL - SF1	Acabado PM - SF4
3/4" x 1/2"	2.00	2.00	T7RWWW-075050PL	T7RWWW-075050PM
1" X 1/2"	2.13	2.13	T7RWWW-100050PL	T7RWWW-100050PM
1" X 3/4"	2.13	2.13	T7RWWW-10075PL	T7RWWW-10075PM
1-1/2" X 1/2"	2.38	2.38	T7RWWW-150050PL	T7RWWW-150050PM
1-1/2" X 3/4"	2.38	2.38	T7RWWW-150075PL	T7RWWW-150075PM
1-1/2" X 1"	2.38	2.38	T7RWWW-150100PL	T7RWWW-150100PM
2 X 1/2"	2.88	2.63	T7RWWW-200050PL	T7RWWW-200050PM
2" X 3/4"	2.88	2.63	T7RWWW-200075PL	T7RWWW-200075PM
2" X 1"	2.88	2.63	T7RWWW-200100PL	T7RWWW-200100PM
2" X 1-1/2"	2.88	2.63	T7RWWW-200150PL	T7RWWW-200150PM
2-1/2" X 1/2"	3.13	2.88	T7RWWW-250050PL	T7RWWW-250050PM
2-1/2" X 3/4"	3.13	2.88	T7RWWW-250075PL	T7RWWW-250075PM
2-1/2" X 1"	3.13	2.88	T7RWWW-250100PL	T7RWWW-250100PM
2-1/2" X 1-1/2"	3.13	2.88	T7RWWW-250150PL	T7RWWW-250150PM
2-1/2" X 2"	3.13	2.88	T7RWWW-250200PL	T7RWWW-250200PM
3" X 1/2"	3.38	3.13	T7RWWW-300050PL	T7RWWW-300050PM
3" X 3/4"	3.38	3.13	T7RWWW-300075PL	T7RWWW-300075PM
3" X 1"	3.38	3.13	T7RWWW-300100PL	T7RWWW-300100PM
3" X 1-1/2"	3.38	3.13	T7RWWW-300150PL	T7RWWW-300150PM
3" X 2"	3.38	3.13	T7RWWW-300200PL	T7RWWW-300200PM
3" X 2-1/2"	3.38	3.13	T7RWWW-300250PL	T7RWWW-300250PM
4" X 1/2"	4.13	3.63	T7RWWW-400050PL	T7RWWW-400050PM
4" X 3/4"	4.13	3.63	T7RWWW-400075PL	T7RWWW-400075PM
4" X 1"	4.13	3.63	T7RWWW-400100PL	T7RWWW-400100PM
4" X 1-1/2"	4.13	3.63	T7RWWW-400150PL	T7RWWW-400150PM
4" X 2"	4.13	3.88	T7RWWW-400200PL	T7RWWW-400200PM
4" X 2-1/2"	4.13	3.88	T7RWWW-400250PL	T7RWWW-400250PM
4" X 3"	4.13	3.88	T7RWWW-400300PL	T7RWWW-400300PM
6" X 3"	5.63	4.88	T7RWWW-600300PL	T7RWWW-600300PM
6" X 4"	5.63	5.13	T7RWWW-600400PL	T7RWWW-600400PM

NOTA: Especificaciones BPE 2019.

Acabado PL – SF1.
D.E. = 32Ra Pulido Mecánico.
D.I. = 20Ra Pulido Mecánico.

Acabado PM – SF4.
D.E. = 32Ra Pulido Mecánico.
D.I. = 15Ra Pulido Mecánico y Electropulido.