

Conexiones Biofarmacéuticas “High Purity”

Tee Extremo Soldable x Extremo Soldable x Clamp - T7WWM

D.E. Tubing	A (in)	B (in)	Acabado PL - SF1	Acabado PM - SF4
1/2"	1.88	2.25	T7WWM-050PL	T7WWM-050PM
3/4"	2.00	2.38	T7WWM-075PL	T7WWM-075PM
1"	2.13	2.63	T7WWM-100PL	T7WWM-100PM
1-1/2"	2.38	2.88	T7WWM-150PL	T7WWM-150PM
2"	2.88	3.38	T7WWM-200PL	T7WWM-200PM
2-1/2"	3.13	3.63	T7WWM-250PL	T7WWM-250PM
3"	3.38	3.88	T7WWM-300PL	T7WWM-300PM
4"	4.13	4.75	T7WWM-400PL	T7WWM-400PM
6"	5.63	7.13	T7WWM-600PL	T7WWM-600PM

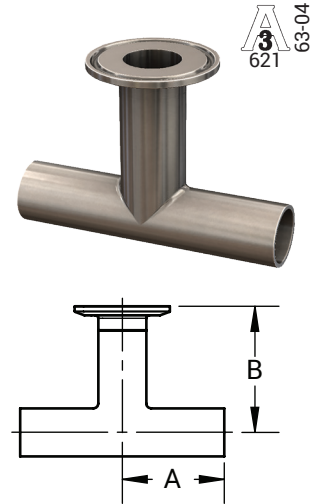

Tee Clamp x Clamp x Clamp - T7MP

D.E. Tubing	A (in)	Acabado PL - SF1	Acabado PM - SF4
1/2"	2.38	T7MP-050PL	T7MP-050PM
3/4"	2.50	T7MP-075PL	T7MP-075PM
1"	2.63	T7MP-100PL	T7MP-100PM
1-1/2"	2.88	T7MP-150PL	T7MP-150PM
2"	3.38	T7MP-200PL	T7MP-200PM
2-1/2"	3.63	T7MP-250PL	T7MP-250PM
3"	3.88	T7MP-300PL	T7MP-300PM
4"	4.75	T7MP-400PL	T7MP-400PM
6"	7.13	T7MP-600PL	T7MP-600PM

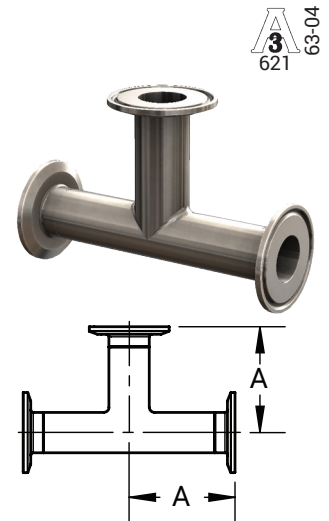

BPE Tabla DT-4.1.2-4
ASME BPE 2019

NOTA: Especificaciones BPE 2019.
Acabado PL – SF1.
D.E. = 32Ra Pulido Mecánico.
D.I. = 20Ra Pulido Mecánico.

Acabado PM – SF4.
D.E. = 32Ra Pulido Mecánico.
D.I. = 15Ra Pulido Mecánico y Electropulido.